

 **PT SELAMAT SEMPURNA Tbk**
MANUFACTURER OF AUTOMOTIVE PARTS
MEMBER OF ADR GROUP - AUTOMOTIVE DIVISION

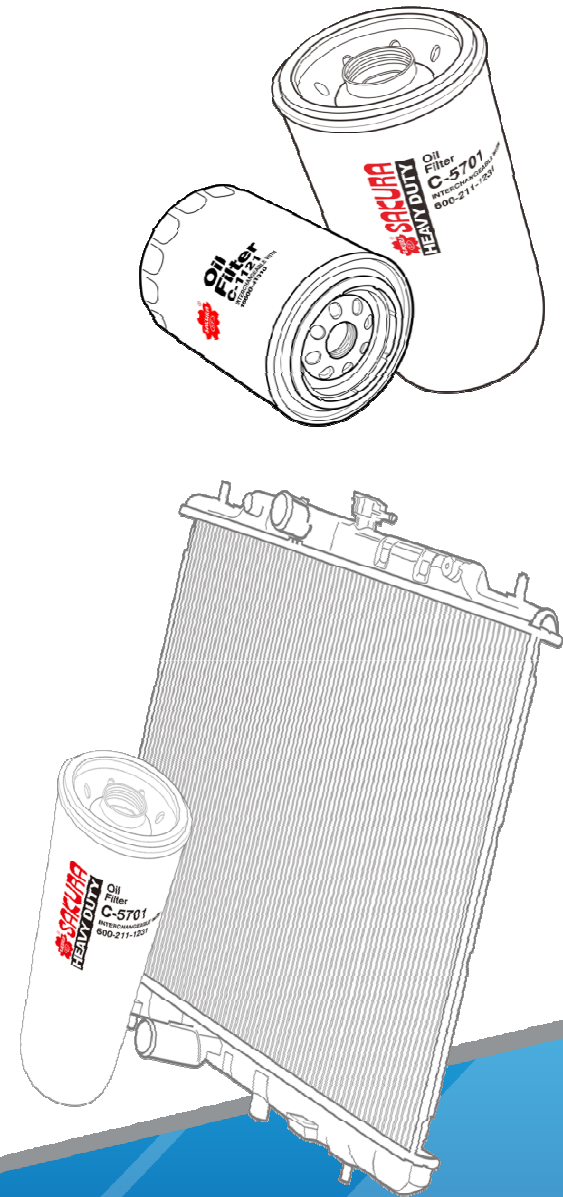

Investor Relations
1H 2018 Performance

Fact Sheet about PT Selamat Sempurna Tbk

- ❑ PT Selamat Sempurna Tbk is the flagship of ADR Group (Automotive Division)
- ❑ The Largest Filter Manufacturer in the region
- ❑ The Most Comprehensive range of products
- ❑ Serve more filtration and radiator products than any other auto component company
- ❑ Exported to more than **120** countries worldwide
- ❑ Trademark Registration in more than **100** countries worldwide
- ❑ Over 90% of our revenue is recurring aftermarket revenue
- ❑ Strong Balance Sheet and Cash Flow

Production Plant - Indonesia



Kapuk Plant (Radiator Facilities)



Tangerang Plant (Filter Other Products & Subsidiaries)

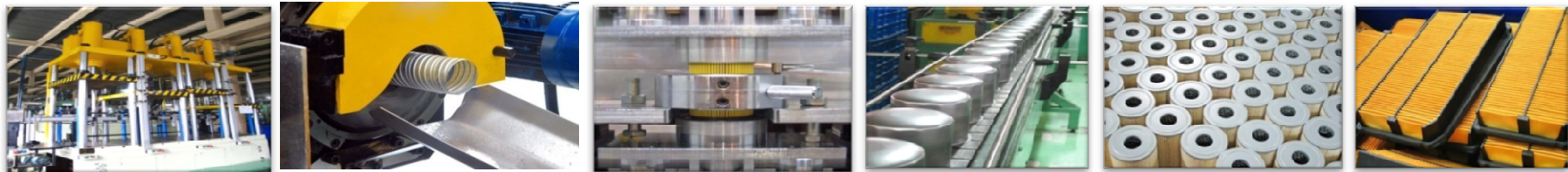

▪ **Filters : 96 millions pieces per year**

▪ **Radiators: 1.95 millions pieces per year**

Product Range

- *With more than 8,000 part numbers available for automotive and heavy duty applications, we serve wide range of products than any other auto component company.*
- *With additional \pm 500 part numbers every year.*



Brand Names

Our Product brand names are well recognized in the after market as well as OEM & OES, both locally and internationally. Some of our brand names are:



SAKURA
Filtration Product



RADIATOR



DUMP HOIST



COOLANT



BRAKE PARTS

List of OEM/OES

- ATLAS COPCO
- CARRIER
- CASE NEW HOLLAND
- CHEVROLET
- DAIHATSU
- DOOSAN
- FOTON
- HINO
- HITACHI
- HONDA
- HYUNDAI
- ISUZU
- JCB
- KIA
- KOBELCO
- KUBOTA
- LINDE
- MAN
- MANITOU
- MAZDA
- MITSUBISHI
- NISSAN
- SUMITOMO
- SUZUKI
- TAKEUCHI
- TCM
- TEREX
- TOYOTA
- UD TRUCKS
- VOLVO
- YALE
- YANMAR
- etc

Technical Assistance

Filters

- **1984:** Donaldson Company Inc., USA (PT Panata Jaya Mandiri)
- **1985:** Mahle Japan Limited, Japan. (formerly Tsuchiya Manufacturing Co. Ltd., Japan)
- **1988:** Tokyo Roki Co., Ltd., Japan (PT Selamat Sempurna Tbk)

Radiators & Others

- **1979:** Tokyo Radiators Mfg. Co. Ltd., Japan
(Radiator - PT Selamat Sempurna Tbk)
- **1982:** Usui Kokusai Sangyo Kaisha Ltd., Japan
(Brake Pipes - PT Selamat Sempurna Tbk.)
- **1989:** ShinMaywa Industrial Co. Ltd., Japan.
(PT Hydraxle Perkasa)
- **2013:** Sueyoshi Kogyo Co. Ltd., Japan.
(Fuel Tank and Hydraulic Tank for Construction Machinery – PT Selamat Sempurna Tbk)

25 Years Consecutive Sales Growth

No	Year	Net Sales
	1992	21
1	1993	24
2	1994	78
3	1995	102
4	1996	127
5	1997	161
6	1998	350
7	1999	359
8	2000	503
9	2001	565
10	2002	603
11	2003	638
12	2004	731
13	2005	862
14	2006	881
15	2007	1.064
16	2008	1.354
17	2009	1.375
18	2010	1.562
19	2011	2.072
20	2012	2.269

No	Year	Net Sales
21	2013	2.382
22	2014	2.633
23	2015	2.803
24	2016	2.880
25	2017	3.340

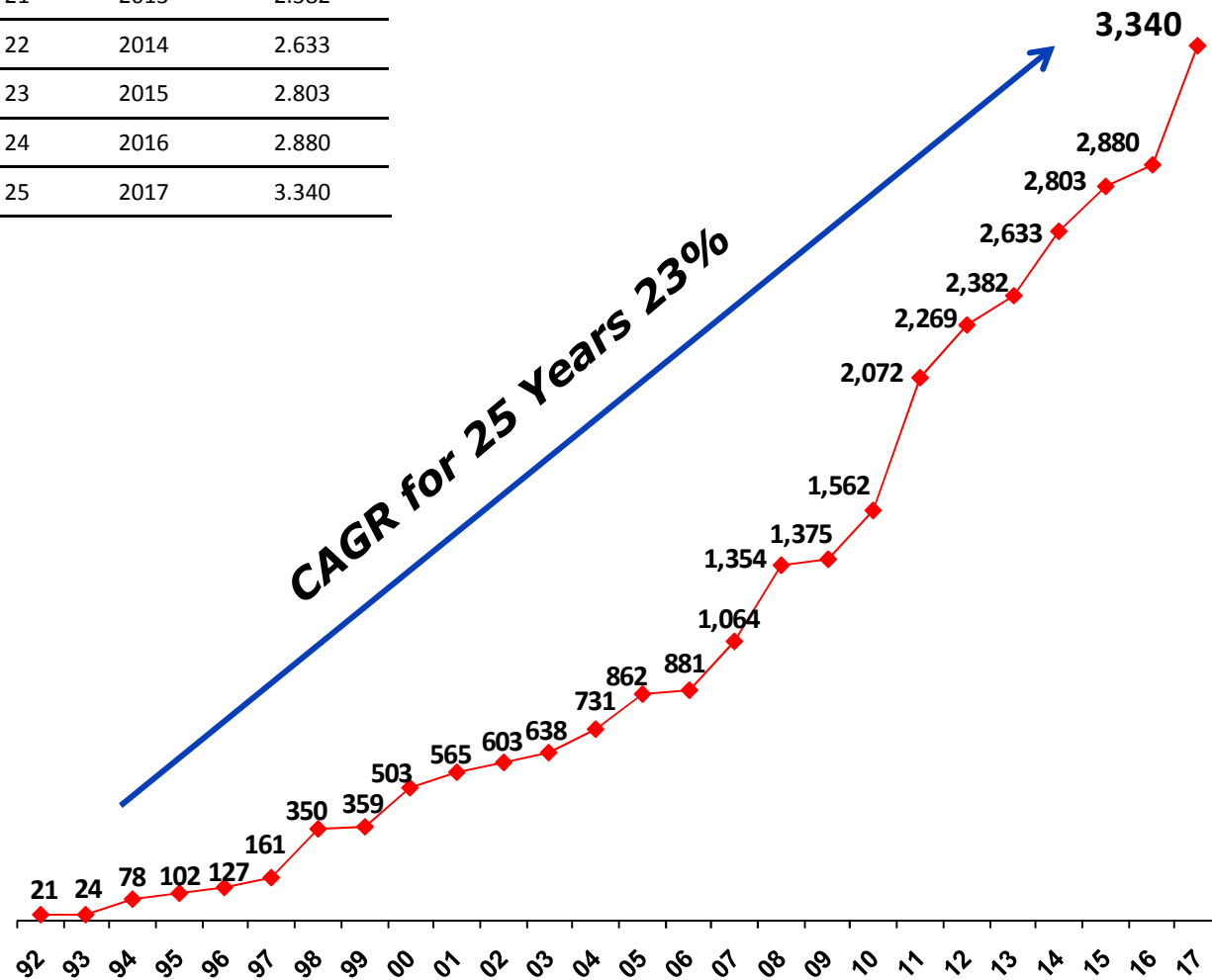

15 Years Consecutive Net Income

No	Year	Net Income
	2002	40
1	2003	48
2	2004	57
3	2005	66
4	2006	66
5	2007	80
6	2008	91
7	2009	133
8	2010	150
9	2011	212
10	2012	219
11	2013	308
12	2014	390
13	2015	428
14	2016	453
15	2017	499

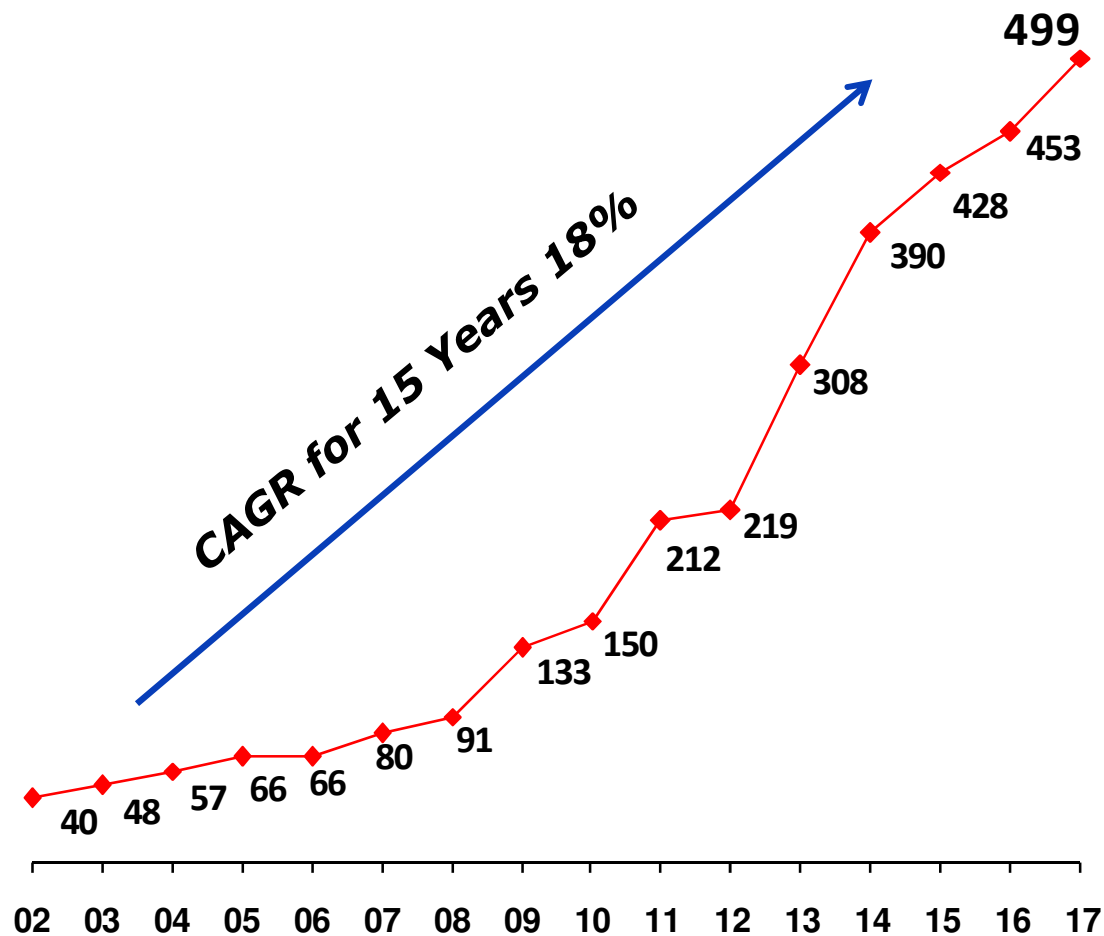

Amount in Billion Rupiah

18 Years Consecutive Export Sales Growth

No	Year	Export Sales
	1999	249
1	2000	340
2	2001	379
3	2002	425
4	2003	462
5	2004	542
6	2005	650
7	2006	695
8	2007	829
9	2008	1.027
10	2009	1.035
11	2010	1.139
12	2011	1.317
13	2012	1.339
14	2013	1.479
15	2014	1.832
16	2015	2.042
17	2016	2.051
18	2017	2.324

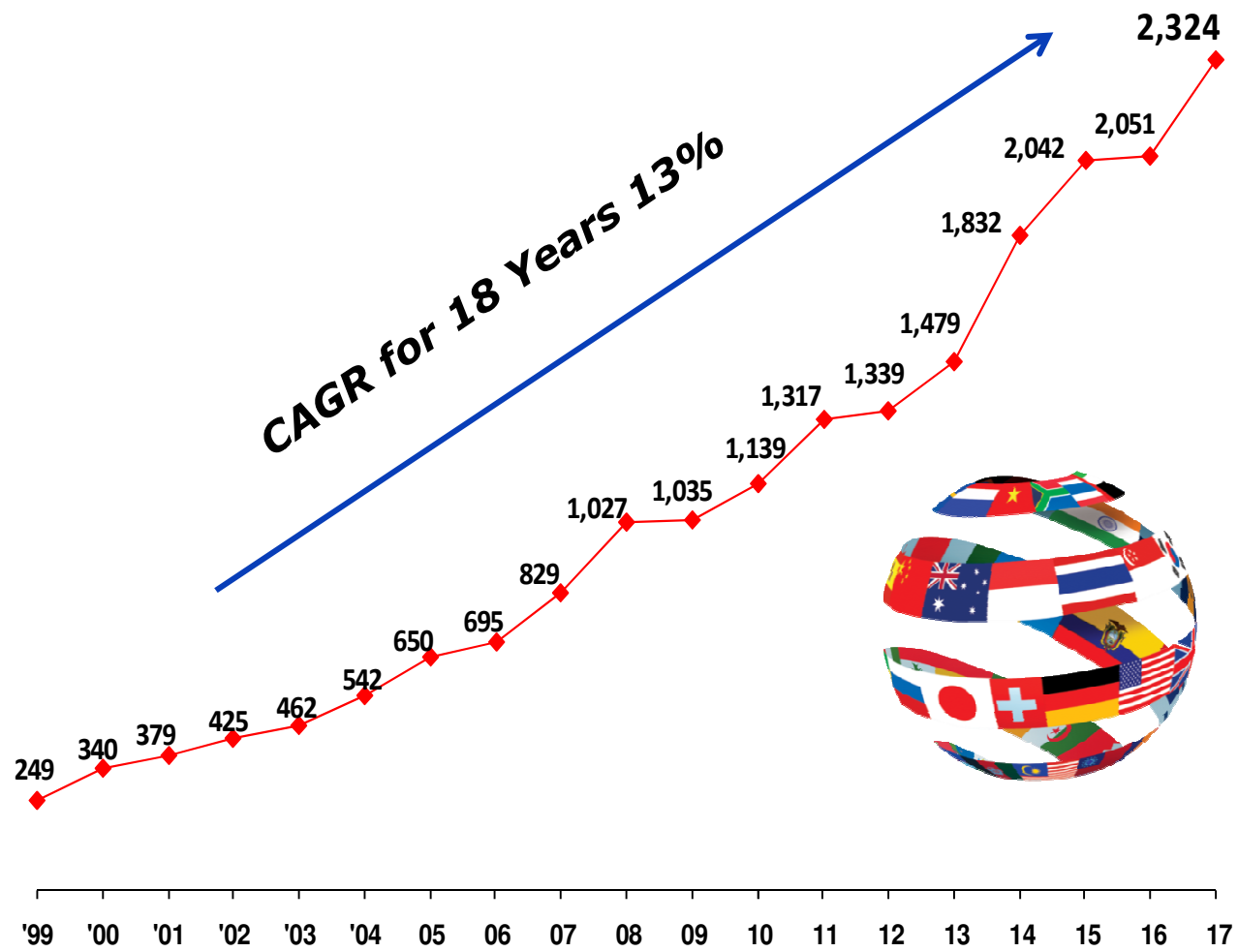

13 Years Consecutive Dividend Payment Growth

No	Book Year	Total Dividend (In Bio IDR)	Net Income (In Bio IDR)	Payout Ratio
	2004	25,97	57	45%
1	2005	32,47	66	49%
2	2006	41,08	66	62%
3	2007	57,59	80	72%
4	2008	86,38	91	94%
5	2009	129,57	133	98%
6	2010	136,77	150	91%
7	2011	143,97	212	71%
8	2012	151,27	219	65%
9	2013	165,56	308	54%
10	2014	179,96	390	46%
11	2015	215,95	428	50%
12	2016	266,34	453	59%
13	2017	299,45	499	60%
	2018	143,97*	221	65%

DIVIDEND POLICY, Dividend percentage of net income are:

- Net income up to Rp 10 billion : 35% ;
- Net income above Rp 10 billion - Rp 30 billion : 40% ;
- Net income above Rp 30 billion : 45%.

- Paid quarterly dividend since 2016
- Increased annually for 13 years

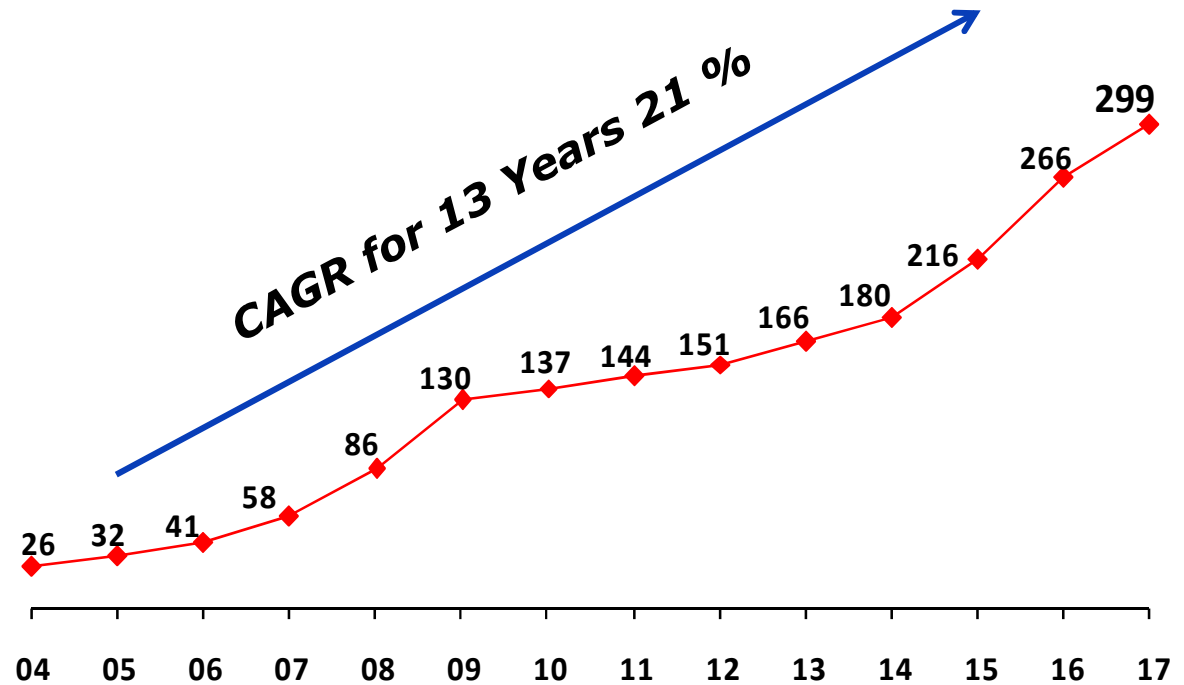



Dividend Distribution on year 2018 :

Final Dividend For Book Year 2017 : IDR 69 Bio on June 08, 2018

*** 1st Interim Dividend For Book Year 2018 : IDR 58 Bio on May 25, 2018**

2nd Interim Dividend For Book Year 2018 : IDR 86 Bio on Aug 28, 2018

Summary Performance 1H 2018

	Position as per 30 June 18		Changes
Net Sales	IDR 1.793 T		20%
Profit for the Period*	IDR 221 B		4%
EPS	IDR 38		4%

** Attributable to Owners of the parent entity*

Comparative Financial Highlights

	6 Months Ended		Compare Q to Y	
	1H'18	1H'17	1H'18	2017
Net Sales	1,793	1,494	1,793	3,340
Gross Profit	494	439	494	1,007
Profit for the period attributable to :				
Owners of the parent entity	221	213	221	499
Non-controlling Interest	34	26	34	56
Total Assets	2,714	2,331	2,714	2,443
Total Current Assets	1,776	1,508	1,776	1,570
Total Current Liabilities	548	461	548	420
Total Liabilities	756	634	756	615
Equity attributable to :				
Owners of the parent entity	1,693	1,486	1,693	1,592
Non-controlling Interest	265	211	265	236
Earnings per Share	38	37	38	87

Financial Ratio

	Compare Q to Q		Compare Q to Y	
	1H'18	1H'17	1H'18	2017
Net Sales Growth	20%			
Total Asset Growth	16%		11%	
Total Equity Growth	15%		7%	
Gross Profit Margin	28%	29%	28%	30%
Operating Profit Margin	18%	20%	18%	20%
Net Income Margin *)	12%	14%	12%	15%
Return on Assets	9%	10%	9%	23%
Return on Equity *)	13%	14%	13%	31%
Total Debt / Total Assets	28%	27%	28%	25%
Total Debt / Equity	39%	37%	39%	34%
Current Ratio	324%	327%	324%	374%

Sales Performance 1H 2018 (6 Months Ended)

Market	Sales (Rp)				Increase /(Decrease)	
	1H'18	%	1H'17	%	Rp	%
Indonesia	607	34%	463	31%	144	31%
Overseas	1.186	66%	1.031	69%	155	15%
Total	1.793	100%	1.494	100%	299	20%

Product	Sales (Rp)				Increase /(Decrease)	
	1H'18	%	1H'17	%	Rp	%
Filter	1.298	72%	1.079	72%	219	20%
Radiator	151	8%	161	11%	(10)	(6%)
Body Maker	160	9%	92	6%	68	73%
Trading	418	23%	368	25%	50	14%
Others	195	11%	162	11%	33	20%
(Elimination)	(428)	(24%)	(368)	(25%)	(60)	(16%)
Total	1.793	100%	1.494	100%	300	20%

Sales by Region

Continent	6 Months Ended				
	1H 2018		1H 2017		Inc / (Dec)
	Rp	%	Rp	%	
Indonesia	607	34%	463	31%	31%
Asia	572	32%	533	36%	7%
America	238	13%	249	17%	(4%)
Europe	210	12%	175	12%	20%
Australia	142	8%	54	4%	161%
Africa	24	1%	20	1%	19%
Total	1.793	100%	1.494	100%	20%



Investment Activity 6 Months Ended in 2018

June 2018 :

on Friday, 29 June 2018, PT Selamat Sempurna Tbk, has signed a Share Purchase Deed related to Share Purchase Transaction in Sure Filter Thailand Co., Ltd (“SF-Thailand”), a Company registered and incorporated under the laws of Thailand .

Total value of transaction, amounting **THB.55.000.000,-** (fifty five Thailand Baht) or equivalent to Rp.23.738.000.000,- (twenty three billion seven hundred thirty eight million Rupiah), which is represented 44.00% shareholding in SFT. As for the composition of shareholders after the transaction is as follows:

Shareholders	Before Transaction		After Transaction	
	Number of Share	%	Number of Share	%
Phuchit Thanakorncharean	299,000	46	299,000	46
Phirunlak Wongsawan	32,500	5	32,500	5
Fu-Tung Jan	32,500	5	32,500	5
PT Adrindo Intisarana	286,000	44	-	-
PT Selamat Sempurna Tbk	-	-	286,000	44
Total	650,000	100	650,000	100

The view of the inclusion of SF Thailand in the SMSM Performance will started since July 2018 and reflected on 3rd Quarter 2018 Result

Investment Activity continue

Independent parties engaged in connection with the Transaction and appointed by the Company are as follows:

The Company had appointed Public Appraiser Office (Kantor Jasa Penilai Publik) Iskandar dan Rekan (hereinafter referred to as "Appraiser") as independent appraiser to provide fairness opinion on the Transaction. The Appraiser declares having no affiliated relation either directly or indirectly with the Company as defined under the Law of Capital Market.

Approval from Creditors :

In connection with the implementation of the Transaction, the Company obtains approval from its creditors as follow:

1. PT Bank Central Asia Tbk - Letter No. 40217/GBK/2018 dated on June 28, 2018
2. PT Bank Mizuho Indonesia – Letter dated on June 28, 2018

Nature of Affiliated relations based on share ownerships structure:

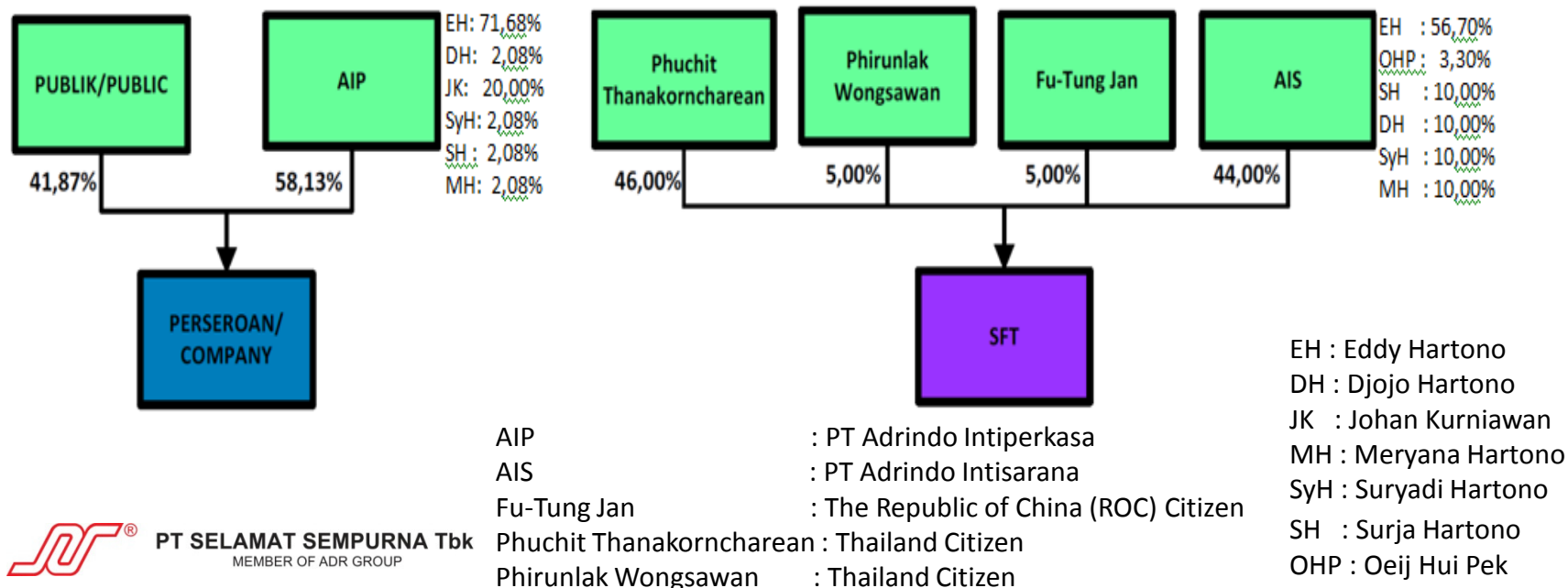

Structure of Company with the Subsidiaries and Associates

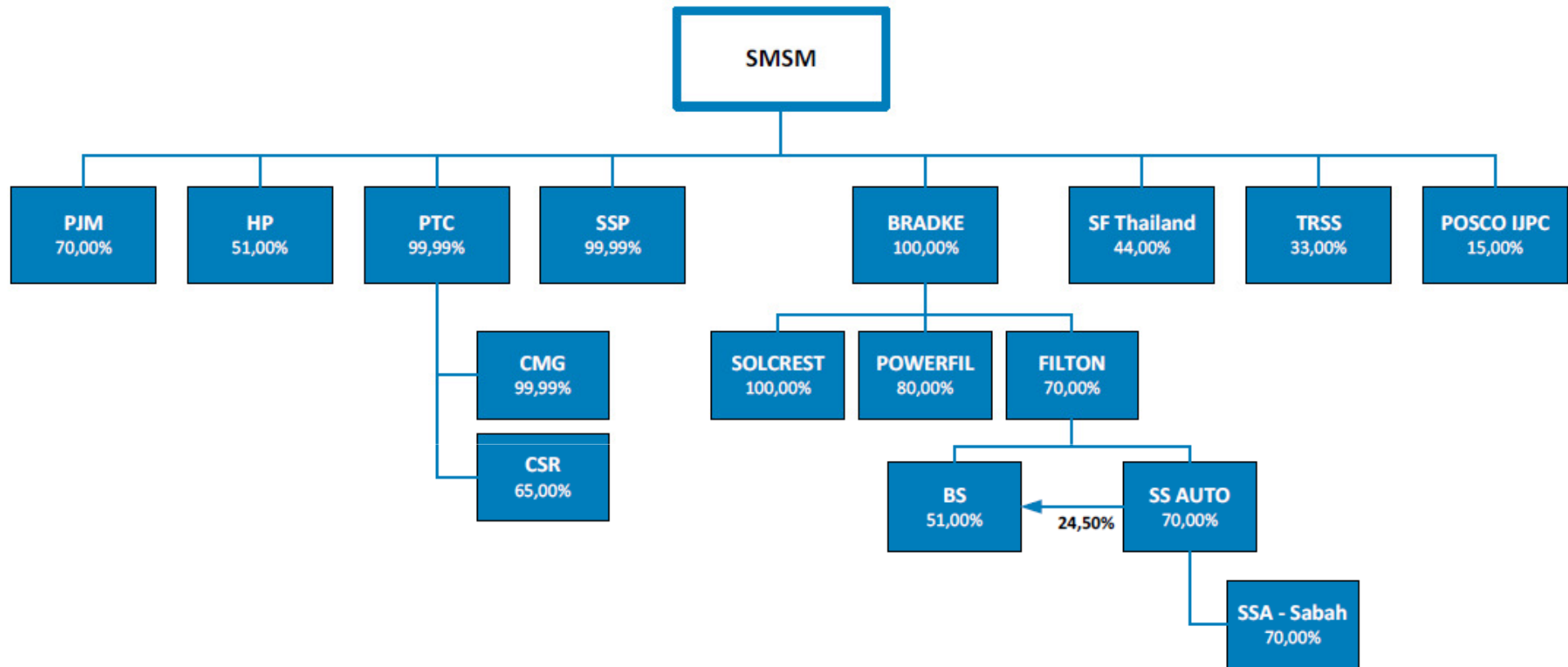

Manufacture :

PJM : PT PANATA JAYA MANDIRI
HP : PT HYDRAXLE PERKASA
SSP : PT SELAMAT SEMPANA PERKASA
TRSS : PT TOKYO RADIATOR SELAMAT SEMPURNA
POSCO IJPC : PT POSCO INDONESIA JAKARTA PROCESSING CENTER
FILTON : FILTON INDUSTRIES SDN BHD

Distribution :

PTC : PT PRAPAT TUNGGAL CIPTA
CMG : PT CAHAYA MITRA GEMILANG
CSR : PT CAHAYA SEJAHTERA RIAU
SOLCREST : SOLCREST PTY LTD
POWERFIL : POWERFIL AUTOPARTS SDN BHD
SS AUTO : SS AUTO SDN BHD
BS : BS ENTERPRISE SDN BHD
SS A-Sabah : SS AUTO (Sabah) SDN BHD
SF Thailand : SURE FILTER THAILAND CO., LTD



PT Panata Jaya Mandiri – PJM (Subsidiary Company)

- ❑ SMSM owns a 70% stake in PJM
- ❑ *Joint venture* with Donaldson Company Inc., USA

Financial Highlights	1H'18(U)	1H'17(U)	Inc/ (Decr) %
Net Sales	428	344	24%
Gross Profit	90	80	12%
Income From Operations	73	66	11%
Profit for the period	58	49	19%
Current Asset	359	297	21%
Total Asset	463	375	24%
Current Liabilities	103	113	(9%)
Total Liabilities	135	135	(-1%)
Total Equity	328	239	37%

U = Unaudited

Amount in Billion Rupiah



PT Hydraxle Perkasa – HP (Subsidiary Company)

- ❑ SMSM owns a 51% stake in HP
- ❑ Manufacture dump hoist and body maker of dump truck, trailer, mixer, and tank

Financial Highlights	1H'18(U)	1H'17(U)	Inc/ (Decr) %
Net Sales	184	115	61%
Gross Profit	41	22	82%
Income From Operations	32	17	84%
Profit for the period	24	13	85%
Current Asset	147	103	43%
Total Asset	222	179	24%
Current Liabilities	36	26	36%
Total Liabilities	48	39	25%
Total Equity	174	140	24%

U = Unaudited

Amount in Billion Rupiah





PT Prapat Tunggal Cipta– PTC (Subsidiary Company)

- ❑ SMSM owns a 99.9% stake in PTC
- ❑ Sole distributor that specializes on the trading of the Company products in Indonesia aftermarket sectors.

Financial Highlights	1H'18(U)	1H'17(U)	Inc/ (Decr) %
Net Sales	212	199	7%
Gross Profit	50	46	10%
Income From Operations	29	25	17%
Profit for the Period	22	19	18%
Current Asset	201	170	18%
Total Asset	209	178	18%
Current Liabilities	55	32	74%
Total Liabilities	60	35	71%
Total Equity	149	142	5%

U = Unaudited

Amount in Billion Rupiah



PT Selamat Sempurna Perkasa – SSP (Subsidiary Company)

- ❑ SMSM owns a 99.9% stake in SSP
- ❑ manufacturers rubber O-rings, polyurethanes, and plastisol adhesives for automotive industries

Financial Highlights	1H'18(U)	1H'17(U)	Inc/ (Decr) %
Net Sales	103	97	7%
Gross Profit	15	13	13%
Income From Operations	12	10	18%
Profit for the Period	9	8	13%
Current Asset	64	63	3%
Total Asset	88	83	6%
Current Liabilities	13	16	(16%)
Total Liabilities	18	20	(7%)
Total Equity	70	64	10%

U = Unaudited

Amount in Billion Rupiah

Bradke Synergies Sdn Bhd – BRADKE (Subsidiary Company)

- ❑ SMSM owns a 100,00% stake in Bradke
- ❑ Bradke is the Holding Company which had subsidiaries of which are (i) Manufacturing of filters product & the Company's Supplier for machinery (Filton Industries Sdn Bhd), the Company's sole distributor of filter products in Malaysia & Australia (Powerfil Auto Parts Sdn Bhd , SS Auto Sdn Bhd , Solcrest Pte Ltd)

Financial Highlights	1H'18 (U)	1H'17 (U)	Inc/ (Decr) %
Net Sales	69	63	9%
Gross Profit	26	24	11%
Income From Operations	9	9	3%
Profit for the period	7	6	9%
Current Asset	76	73	4%
Total Asset	132	131	1%
Current Liabilities	28	27	3%
Total Liabilities	40	42	(5%)
Total Equity	92	89	4%

U= Unaudited

Amount in Million Ringgit Malaysia

Sure Filter Thailand – SF THAILAND (Associate Company)

- ❑ SMSM owns a 44,00% stake in SF Thailand [acquire on June 29, 2018]
- ❑ SF Thailand is the Company's sole distributor of filter and radiator products in Thailand

Financial Highlights	1H'18 (U)	1H'17 (U)	Inc/ (Decr) %
Net Sales	137	114	21%
Gross Profit	37	22	65%
Income From Operations	9	3	260%
Profit for the period	12	4	182%
Current Asset	164	129	26%
Total Asset	246	202	22%
Current Liabilities	66	84	(21%)
Total Liabilities	123	109	13%
Total Equity	123	93	33%

The view of the inclusion of SF Thailand in the SMSM Performance will started since July 2018 and reflected on 3rd Quarter 2018 Result

PT POSCO Indonesia Jakarta Processing Center (Associate Company)

- SMSM owns a 15% stake in POSCO IJPC
- Joint venture* with POSCO and DAEWOO International Corporation

Financial Highlights	1H'18(U)	1H'17(U)	Inc/ (Decr) %
Net Sales	48.21	41.75	15%
Gross Profit	2.15	1.89	14%
Income From Operations	0.82	0.62	33%
Net Income	(0.66)	0.20	(421%)
Current Asset	48.22	50.60	(5%)
Asset	62.32	65.83	(5%)
Current Liabilities	48.94	52.26	(6%)
Liabilities	49.36	52.58	(6%)
Equity	12.95	13.25	(2%)

U = Unaudited

Amount in Million USD



PT Tokyo Radiator Selamat Sempurna (Associate Company)

- ❑ SMSM owns a 33% stake in TRSS
- ❑ *Joint venture* with Tokyo Radiator Mfg. Co. Ltd

Financial Highlights	1H'18(U)	1H'17(U)	Inc/ (Decr) %
Net Sales	46	38	20%
Gross Profit	12	10	22%
Income From Operations	6	5	20%
Net Income	5	4	15%
Current Asset	67	46	46%
Asset	91	74	24%
Current Liabilities	12	9	28%
Liabilities	14	10	41%
Equity	77	64	21%

U = Unaudited

Amount in Billion Rupiah

Achievement 2018

Month	Achievement
January	<ul style="list-style-type: none">•100 Fastest Growing Companies Awards 2017 in the Sub Sector of Automotive Components of the Miscellaneous Industry Sector by InfoBank.•2018 Indonesia Automotive Component Manufacturer of The Year From Frost&Sullivan
April	<ul style="list-style-type: none">• The Best Vendor Performance 2017 by PT Suzuki Indomobil Motor• Appreciation and Recognition for Good Performance in 2017 by PT Suzuki Indomobil Motor
May	<ul style="list-style-type: none">•Investor Awards 2018 for the category of Best Listed Company 2018 in Diversified Manufacturing Sector

Thank You

visit us : www.smsm.co.id

This presentation has been prepared by PT Selamat Sempurna Tbk independently and is circulated for the purpose of general information only. It is not intended for the specific person who may receive this presentation. The information in this presentation has been obtained from sources which we deem reliable. No warranty (expressed or implied) is made as to the accuracy or completeness of the information. All opinions and estimations included in this presentation constitute our judgment as of this date and are subject to change without prior notice. We disclaim any responsibility or liability whatsoever arising which may be brought or suffered by any person as a result of acting in reliance upon the whole or any part of the contents of this report and neither PT Selamat Sempurna Tbk and/or its affiliated companies and/or their respective employees and/or agents accept liability for any errors, omissions, negligent or otherwise, in this report and any inaccuracy herein or omission here from which might otherwise arise.

Cautionary note on forward-looking statements:

This presentation may contain statements regarding the business of PT Selamat Sempurna Tbk and its subsidiaries that are of a forward-looking nature and are therefore based on management's assumptions about future developments. Forward-looking statements involve certain risks and uncertainties because they relate to future events. Actual results may vary materially from those targeted, expected or projected due to several factors. Potential risks and uncertainties include such factors as general economic conditions, foreign exchange fluctuations, interest rate changes, commodity price fluctuations and regulatory developments. The reader and/or listener is cautioned to not unduly rely on these forward-looking statements. We do not undertake any duty to publish any update or revision of any forward-looking statements.